

The Patrol Books . . No. 6

KNOTTING FOR SCOUTS

by

W. J. GENESE

and illustrated by the author

Published by
THE BOY SCOUTS ASSOCIATION
25, Buckingham Palace Road
London, S.W.1

First Published, 1950
Reprinted, 1951
Reprinted, 1954

Printed by C. Tinling & Co. Ltd., Liverpool, London and Prescott.

Downloaded from:
"The Dump" at ScoutsCan.com
<http://www.thedump.scoutscan.com/>

Thanks to Dennis Trimble for providing this booklet.



Editor's Note:

The reader is reminded that these texts have been written a long time ago. Consequently, they may use some terms or express sentiments which were current at the time, regardless of what we may think of them at the beginning of the 21st century. For reasons of historical accuracy they have been preserved in their original form.

If you find them offensive, we ask you to please delete this file from your system.

This and other traditional Scouting texts may be downloaded from The Dump.

CONTENTS

What B.-P. said about knots
Introductory Notes
Simple Whipping
Sailmaker's Whipping
Definitions, Parts of a Rope
Reef Knot
Half Bow or Slip Reef
Reef Bow
Surgeon's Knot
Sheet Bend and Weaver's Knot
Double Sheet Bend
Slippery Sheet Bend
Clove Hitch
Bowline
Cowboy Bowline
Round Turn and Two Half Hitches
Sheepshank
Double Overhand
Packer's Knot

WHAT B.-P. SAID ABOUT KNOTS

in a Camp Fire Yarn in "Scouting for Boys":

"Every Scout ought to be able to tie knots. To tie a knot seems to be a simple thing, and yet there are right and wrong ways of doing it, and Scouts ought to know the right way. Very often it may happen that lives depend on a knot being properly tied.

"The right kind of knot to tie is one that you can be certain will hold under any amount of strain, and which you can always undo easily if you wish to.

"A bad knot is one which slips away when a hard pull comes on it, or which gets jammed so tight that you cannot untie it.

"The best way to learn is to get a fellow who knows to show you. Knots want a lot of practice as you soon forget them. Use pieces of rope or cord, and not messy bits of string or bootlaces."

INTRODUCTORY NOTES

Have you ever thought of the number of times during the day that you use rope or cord of one kind or another for fastening things, which usually means that you have to make some sort of knot. The material used for the fastenings vary, and it is of different size, to which we give different names, cotton, thread, string, cord or rope, but the same principles apply, whatever we use.

You usually start the day by fastening your shoelaces with a knot, and unless you use your birthday suit or a nightshirt to sleep in, you finish the day by fastening the cord of your pyjama trousers with a knot. Just before you leave home, you find a loose button, and being a Scout, you do not ask your mother to sew it on, but tackle the job yourself. You thread the needle, and then make a thumb knot, a figure of eight, or some other form of stopper knot in the end of the cotton or thread to prevent the end from coming through the doth.

You have to tie up a parcel, to fasten something on the carrier of your bicycle, the clothes line breaks and needs mending, or the clothes airer in the kitchenette is wearing, and must be repaired; all of which needs a knowledge of the use of cord or rope, and the ability to make the proper knots.

So you could go on thinking of dozens of ways in which rope or cord is used either by yourself or those around you, which is done better or more quickly if the person doing the job, knows how.

It is not surprising, therefore, that one of the first things that happen when you join a Scout Troop, is that someone, usually your Patrol Leader, produces some rope from the Patrol box or the Troop store cupboard, and proceeds to teach you some of the simpler knots.

As soon as you start Scout activities you see the added need for this knowledge. When you camp, your house, i.e. your tent, is fastened by cord or rope; you have to put up a line for your blankets to be aired, or to dry your towels and clothing, you need to know many knots and some lashings to be able to make the many gadgets to make yourself comfortable, and to raise your kitchen equipment off the ground, away from the dirt,

But a Scout is nothing if not a pioneer, and so you will learn to make trestles and similar articles, first using thin cord or sisal and fastening Scout staffs together, and later with larger and heavier stuff.

This book is to try and help you to learn about knotting and lashing, to assist you in passing the parts of the Tenderfoot, Second and First Class tests in the pioneering sections shown on the Scout chart No. 11.

Many people can learn how to make knots from a book, but, as B.-P. said, it is better if you can get someone to show you how to do it. When you do it in this way, you will find it much easier if you sit beside your instructor, or stand looking over his shoulder, and then you see the motions in the correct way, and not upside down, as you will if you face the person from whom you are learning.

It helps, too, if you use rope to learn with, and not string or thin cord, as it is easier to see the construction of the various knots when made in rope, although once you have mastered any knot, it is a good idea to try and do the same knot with thinner and thicker stuff. In this way you will be sure of being able to make the knots, whatever material you might have to use.

Another point to remember is that knots are not too difficult to learn, but they are also easy to forget, so it is a good thing to carry about with you a hank of cord, to practice with at odd times.

When Scouting started over forty years ago, no Scout would ever go out in uniform without carrying on his belt, a hank of cord, which served the double purpose of use for practising knots, and to use for emergencies if needed. It is a good thing to see that this custom is being revived in many Patrols.

Speaking of emergencies, reminds you that you might have to make a particular knot quickly, so see how long it takes you to do it, and then practise until you can beat your own time. When you think you have reached the best you can do, then see if you can whack any of the Patrol, especially the Patrol Leader.

But speed is not everything, and it is better to take your time and make the knot correctly, than to do it quickly and wrongly.

Remember, also, you may have to use knots in the dark, to hitch up a car for a tow, or for rescue purposes, so you will practice with your eyes shut, but not behind your back; and to make it really difficult, why not try them when you go swimming, making them under the water.

THE "TENDERFOOT" KNOTS

Now let us make a start with the knots laid down in the Tenderfoot Tests which state that you must:

“Demonstrate with rope how to make the following knots:

Reef knot	Sheet bend
Clove hitch	Bowline
Round turn and two half hitches	Sheepshank

and explain their uses.

Whip the end of a rope.”

We are going to do the last part of the test first, because we may have to use a new piece of rope, just cut from a coil, and if we do not know how to whip the ends, it will start to unravel, with the result that we will be wasting some of the rope, and so breaking the 9th Scout Law, which says “A Scout is thrifty.”

There are several ways of whipping a rope, but one of the easiest ways is called "simple whipping" and we will try one of the many ways of doing this. It is hoped you will try and find other ways of doing it.

SIMPLE WHIPPING

If we use a piece of 1" rope, that is rope of 1" circumference, it will be between ¼" and ⅜" diameter, and we will need thin whipping twine for the job. It is important to have the right kind of stuff to use, as if it is too thick, it may be easier to put on, but we will find it difficult to make it tight enough to prevent it from slipping off in use.

A whipping is not a good one unless it is **TIGHT AND TIDY**. If it is not tight at the start, you will find it will soon start slipping, and will come off some time; and unless each turn lies snugly against the next, without any gaps or overlapping, it does not look a workmanlike job.

Take a couple of feet of whipping twine, double back about 3", lay along the rope, near the end to be whipped, as you can see in A.1. With the long end of the twine, wind it round the rope a dozen or fifteen times, pulling each turn tight, and seeing it is in the correct place. Pass the end S through the loop L as in A.2., taking care you do not let the turns slip in the meantime.

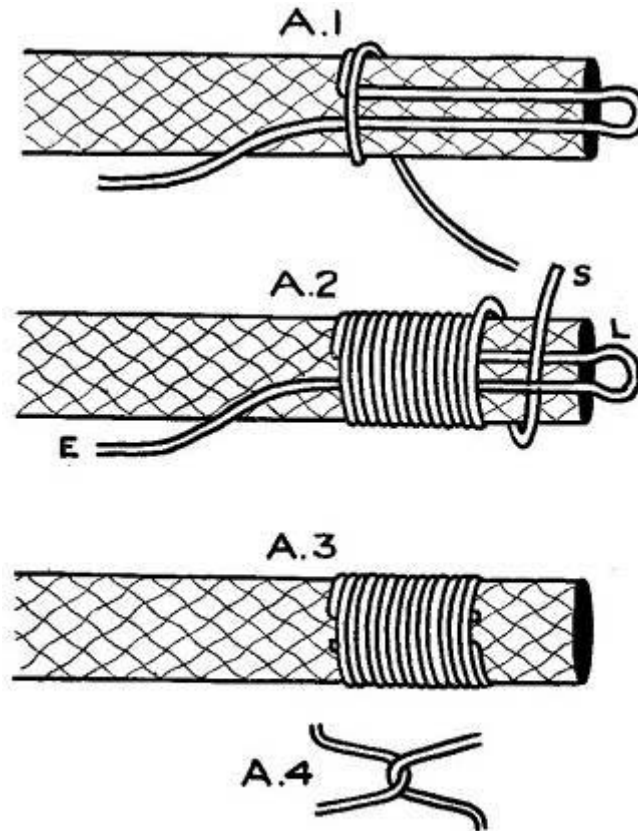

SIMPLE WHIPPING

Now, pull the end E, gently, or you may break the twine; until the loop is about half way through the turns of the whipping, and this will lock the ends like you see in the little sketch A.4.

The final job is to cut off the spare ends, using a sharp knife, close to the turns of the whipping, but taking care to avoid cutting either the rope or the whipping.

If you have done it properly, it will look like the sketch A.3, except that you can see the short ends of the whipping sticking out, which you will not see in yours.

You may not feel too pleased about your first effort, but do not be discouraged, as it is not too easy a job. Have several tries, until you not only make a good job of it, but find you do not take so long to do it.

Then try and get hold of larger ropes and some thicker twine, and practise with that, until you know you are prepared to tackle any sort of rope you may have to use.

SAILMAKER'S WHIPPING

This is a good method of whipping, as you do not have to pull the twine underneath the turns of the whipping, as in the last method, with the risk of snapping the twine.

It cannot be used on braided rope, as shown in the sketches for simple whipping, but, although it may look at first to be a bit complicated, when you have done it a few times, you will be surprised how quickly and neatly you can do it, and probably will prefer it to any other way for whipping laid up rope.

First open the strands near the end of the rope to be whipped, if possible, without unlaying the ends. With some kinds of rope, especially cotton, it is an advantage to put on a temporary whipping, to prevent, not only the rope from coming unlayed, but the strands as well. If this does happen, you will find it difficult, if not impossible to make a good job.

Put the end of the twine between two strands of the rope, pass it round the third strand, and bring it out again between the strands through which it entered, A.5.

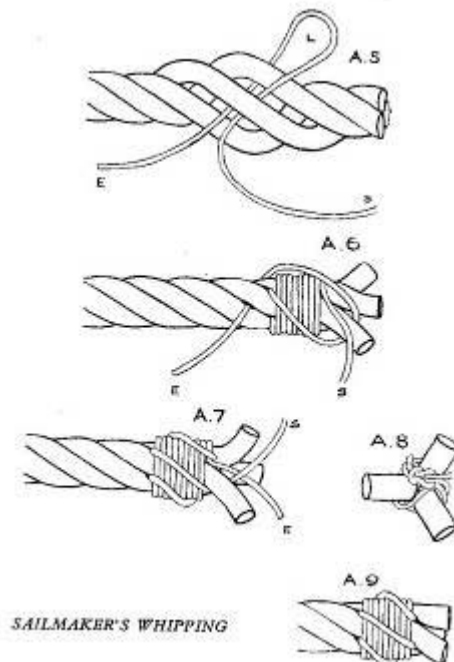

Close the strands again, leaving the large loop, L, in the twine, and some inches of the end of the twine free; make several turns, **TIGHT AND TIDY**, working towards the end of the rope.

Then without letting these turns become loose, put the loop, L over the end of the same strand round which you first passed the twine.

It is most important that you do this correctly, so here it is again, in capitals, to remind you.

PUT THE LOOP L OVER THE END OF THE SAME STRAND ROUND WHICH YOU FIRST PASSED IT, A.6.

Pull the end E until the twine is quite tight against the turns of the whipping, and is also lying snugly between the strands of the end of the rope. You may have to force open the strands to get the twine down into its proper place.

Bring the end E up to the end of the rope, and between the strands of the end, to meet the standing part S, as you see in A.7.

To finish off, join these two with a reef knot, pulling each part of the reef very tightly, making sure there is no slack; cut off the ends very short, A.8; force the strands together again, which has the effect of hiding the reef knot, and the finished whipping should look something like A.9.

In all the sketches for both whippings, in order to make them easier to follow, the twine has been shown much larger than it should be.

Unless you are very skilful, you will not be able to do a good whipping the first time, or perhaps the tenth, so keep on practising, until you can do it easily and quickly.

DEFINITIONS

Knot	Anglo-Saxon	Cnotta
	Dutch	Knot
	German	Knotten

The interlacement or intertwining of a rope or ropes, cord etc., so as to fasten one part to another part of the rope etc., or to another object.

Bend	Anglo-Saxon	Benden
	Icelandic	Benda, to join, strain
	Old Teutonic	Bandjan

To fasten, to make fast, to tie into a knot,

Hitch

Various species of a knot by which a rope is bent to another rope or to a spar.

PARTS OF A ROPE

Just before we start to make the knots, we must know the parts of a rope, and then we can understand the descriptions which are given with the sketches, to help us make them.

End, running or working end. It is obvious what part this is, and you will see it in the sketches, with a whipping on it.

Bight or loop. This is the part of a rope which is doubled back on itself, or crossed over to make a loop, both of which are shown here. This is the start of many knots bends or hitches.

Standing part. The part of the rope which is not used, either because it is fastened to another rope or spar; or because it is too long to be used conveniently. In the sketches, it is shown

without a whipping, meaning that it continues for some distance, but the paper is not large enough to show it all.

Now we know the kind of stuff we are using for our knots, and have learnt to whip the ends, and also know the names of the parts of the rope, we will get on with the first batch of knots, and so qualify for one part of the test which you must pass before you can become a Scout.

REEF KNOT

This is frequently the first knot which a boy learns when he starts his Scouting, if he has not already learnt to make it in the Cub Pack. It is a simple knot to make but very useful, for joining two pieces of string or cord of equal thickness, but not recommended if you want to join ropes. As it is a neat and flat knot it is always used to fasten the ends of a triangular bandage. It fulfils the conditions of a good knot because it: –

1. Can be made easily and quickly.
2. Does its job properly.
3. Holds fast.
4. Does not jamb.
5. Can be untied easily.

The sketches show you how to tie it, but if you cannot work from them get your P.L. or Scouter to help and in any case, when you have mastered it you will have to demonstrate to them that you can do it quickly the first time and without fumbling. When it is finished and pulled up you must have sufficient ends showing to prevent it slipping but not so long that they hang down and look untidy. Remember the reef knot is for fastening the ENDS of the ropes.

This knot, like most of those in this book, is a basic knot from which many others are developed.

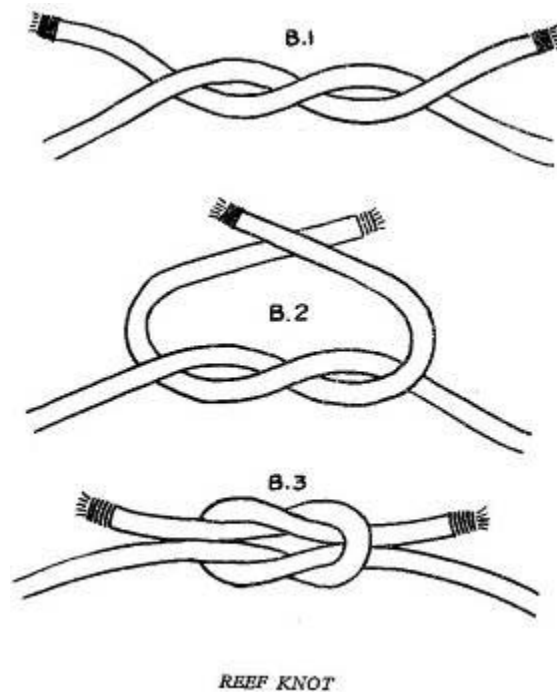

HALF BOW OR SLIP REEF

If you want to untie the reef knot easily you make what is called a half bow by making it look like B.4.

This is useful for parcels which have to be tied and untied frequently and we use it for brailing up our tents.

If the long end is tucked out of sight in the canvas, leaving the other end hanging down, it can be pulled quickly and the brailing will fall of its own weight, which you will find most useful if you have a sudden shower of rain and want to avoid getting the gear in the tent wet.

REEF BOW

B.5 shows quite dearly what this looks like and it is formed by making the second half of the reef with small bights or loops instead of ends. This knot also, like the half bow, is used for parcels,, but Scouts always use it for tying their shoelaces. It is an amusing observation practice to see how many people, including an occasional Scout, use a grannie bow for their shoes.

SURGEON'S KNOT

We find sometimes when we make the first turn> as shown in B.I, that our cord slips, but we can make it hold by giving the two parts an extra turn before crossing the ends over as in B.2.

Because this method was used for the purpose of making the gut hold in sewing up a wound, or after a surgical operation, it is called a surgeon's knot.

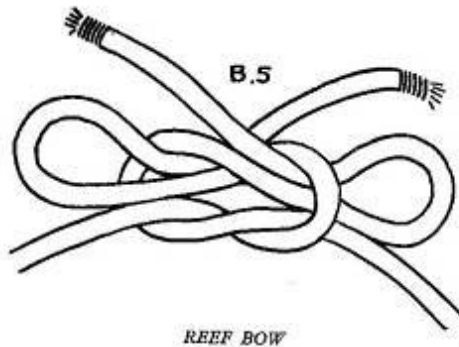
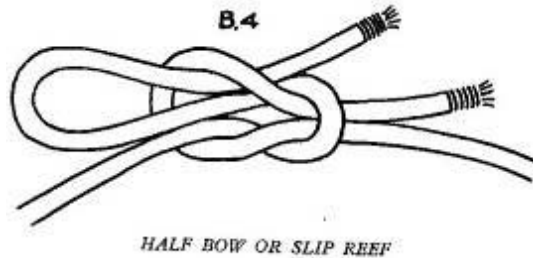

SHEET BEND

This knot we use to join two ropes of unequal thickness, or to make a rope fast to a loop, as we do when we fasten the halyard to the loop on a nag for hoisting. It is well to remember, however, that a sheet bend is often better than a reef, even though we want to join two cords or ropes of the same thickness.

To make a sheet bend a loop is first formed with the thicker rope, the thinner is threaded through this loop, C.1., passed right round the standing part and end of the thicker rope, C.2., tucked under as in C.3., and tightened by pulling on the standing part of the thin rope, C.4. You can see how the thin rope jams against the loop of the thick rope to prevent it from slipping.

WEAVER'S KNOT

For joining two pieces of thread, the sheet bend is tied in a different way – and the two ends come out on the same side of the standing part so they can be snipped off with scissors. It is then called the Weaver's knot.

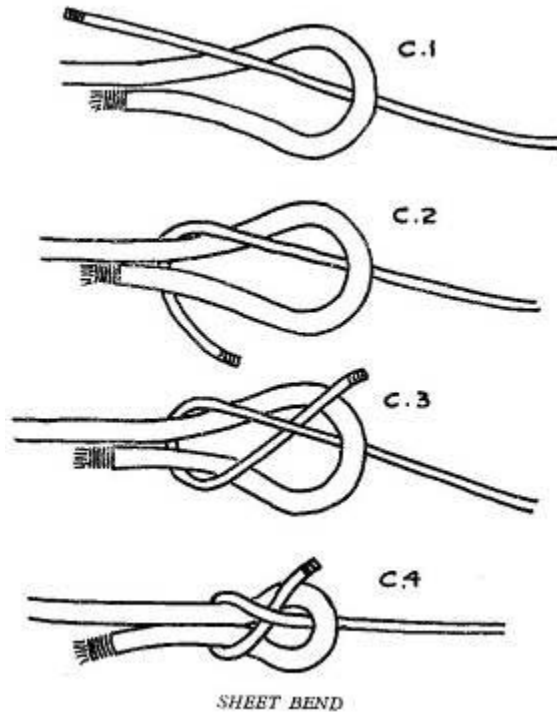

DOUBLE SHEET BEND

If the two ropes are of very different thicknesses there is a risk with the sheet bend, unless the tension on it is steady, that it may not hold fast, so in this case we make another turn with the thin rope and tuck it a second time between itself and the loop as in C.5. This is a safer method of fastening the halyards to a flag, but that is only one of the many uses it has.

SLIPPERY SHEET BEND

To enable you to untie your sheet bend quickly, or if you think it might jamb after being pulled very tightly, or, getting wet, use a slippery sheet bend. This is made by starting in the

normal way as in C.1. and C.2. then, instead of tucking the end, make a small bight or loop in the end of the thin rope and tuck that.

Pull the end of the thin rope and the knot is undone.

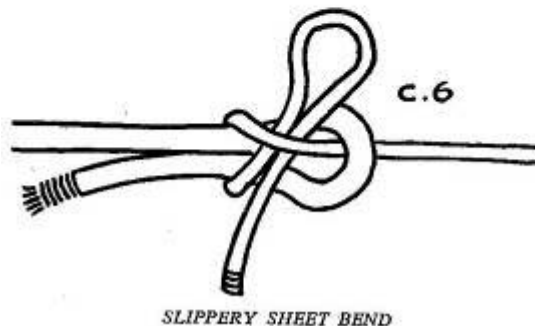
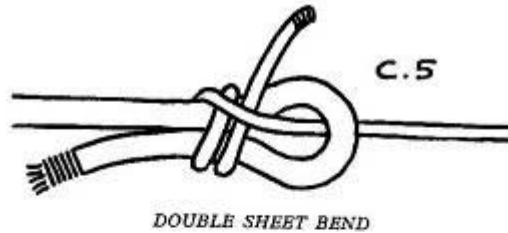

CLOVE HITCH (First Method)

This is a most useful knot and it is the start and finish of some lashings; we use it on the stakes to make our kitchens in camp and for many other purposes.

There are many different ways of making it, some useful, others merely interesting and amusing, but you should try and learn some of them.

We are going to show you only two ways.

This is when you want the hitch in the standing part of a rope to fasten to a spar or pole, where you can get at one end, such as the stakes round your kitchen.

Make two similar loops side by side in the rope, D.1. and D.2, slide them together so that they look like D.3, slip over the spar or pole and pull tight as in D.4.

To be sure this will hold, there should be a tension on each end of the rope.

CLOVE HITCH (Second Method)

The second method is for fastening the end of a rope to a pole, spar or another rope when you cannot get at the end, such as a flag staff, tent pole or tree.

The sketches E.1, 2, 3 and 4 show quite easily how to make the hitch by this method, but It is as well to remember these points. Use only one end of the rope; as you may have to make it sometimes with a very long rope which must continue to be wound round the spar in the same direction. When the two turns are completed, slide the two loops together as in D.4, and pull tight.

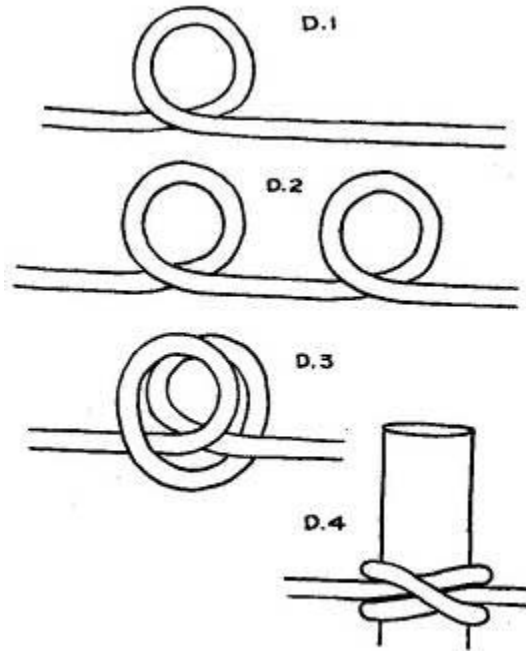

CLOVE HITCH (First Method)

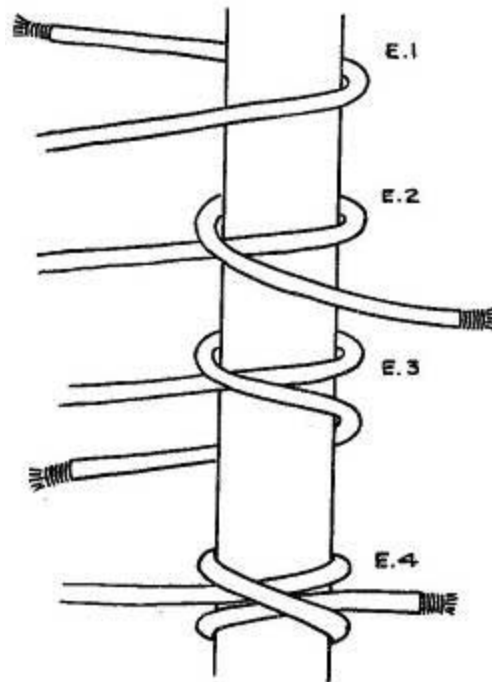

CLOVE HITCH (Second Method)

This may not be secure, especially if the spar on which the hitch is made is smooth, so you are advised to make a half hitch with the end round the standing part of the rope.

When you are sure you can make a clove hitch quickly and correctly by both these methods, find some one to show you how to pick up a clove hitch off the ground using only one hand. You may

want to make a boat fast some time when you are holding on to the bank and this will be a most useful accomplishment.

There are several other ways of making this hitch, and those people who can do them are only too anxious to show you, so you should try and seek them out.

BOWLINE (pronounced bow-lin)

One of the most useful knots anyone can learn to make and although it is said to be used for saving life, fortunately we do not often have to use it for this purpose. We should, however, learn to make it quickly in stout rope with a loop large enough to go round the chest so we can carry out our Scout motto and Be Prepared.

But to make a loop (which will not slip) in the end of a rope, either for the purpose of fastening another rope or cord to it, or to put round or over a fixed object, such as a post or hook, the bowline is one of the best knots to make.

Like the previous knots and bends we have learnt up to now, there are several different ways of making it, but this is the most common.

Make a bight near the end of the rope, F.1, hold the intersection of the two pieces, turn the end down and bring it up through the loop, so that you have a loop in the standing part which passes round the end, F.2. Now pass the end behind the standing part and down through the small loop, F.3, tighten by pulling on the standing part and it should look like F.4.

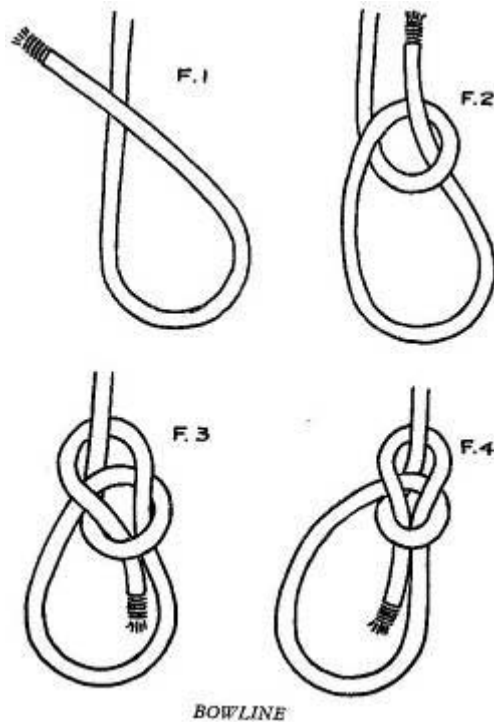

COWBOY BOWLINE

This method of making a bowline was used by cowboys for putting a halter around a horse's neck, hence its names, but it can be used anywhere, if you want to adjust the size of the loop easily before tightening.

To make it, throw a loop, F.5, make a bight in the standing part and put it through this loop, making a slip knot, F.6, and put the end through this bight, F.7. Pull the end of the rope far enough to make the loop the correct size, then push the slip knot over the loop and pull on the standing part to tighten, F.8.

This last step, from F.7 to F.8, is the only difficult part, but you will soon get it if you practise, until you can do it without error, and even with your eyes shut – this last being a good thing to do, in case you have to do it at night in an emergency.

Practise this and the other method round your waist and round other people's waists.

There are at least two more variations of making this knot which you can try and find put for yourself, they cannot all be included in this book or it would be too big.

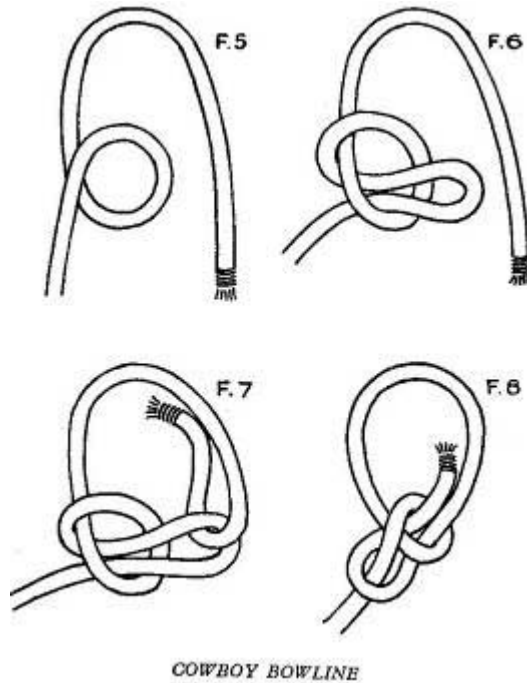

ROUND TURN AND TWO HALF HITCHES

A long name for a simple method of fastening a rope to a spar, or ring, or another rope.

The round turn part of this is shown in G.1 and means that the rope really makes two turns round the spar. You can see from G.2 that the second half, the two half hitches, is like making a clove hitch on the standing part with the free end. Pull tight at this stage and it will then loop something like G.3. Sometimes, the free end is fastened with a light whipping to the standing part for greater security.

One variation of this is to give the rope an extra turn round the spar before making the half hitches.

If you want to find some similar hitches which serve the same purpose as the above, they are called magnus hitch and the fisherman's bend.

An important point to remember is that the pull or tension on the rope in these hitches and bends must be as shown in the sketch, that is, at right angles, or nearly so, to the spar.

If you do not do this, there is a risk that the rope may slip along the spar, especially if the latter is smooth.

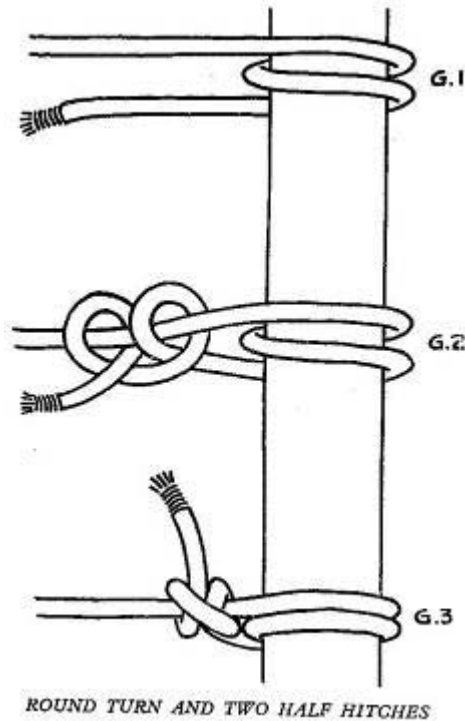

SHEEPSHANK

(First Method)

The last of the tenderfoot knots, not very often used, but can be most useful in certain circumstances. If you have a rope which you want to use quickly, say for a blanket line, and you know it has a weak part, a sheepshank will let you use the rope without it breaking, or if you want to take up the slack in a rope, without unfastening the ends, you can use a sheepshank for this purpose.

To make the sheepshank, double the rope as in H.1, and if it is a damaged rope, the weak part in the middle of the three, make a loop at each end and slip over the doubled portion as in H.2, and pull.

Assume you are using a long rope and so do not use either end of the rope in the process.

(Second Method)

Another way to make this knot is to form three loops in the bight of a rope, I.1, as if you were forming a clove hitch, but with another loop added, and pull each side of the centre loop through an outside loop as shown by the arrows, and it will form the sheepshank as in I.2.

There are several methods of securing this knot to prevent it coming undone, but the simplest way is to put a bight seizing on to each end loop and the standing part lying alongside it.

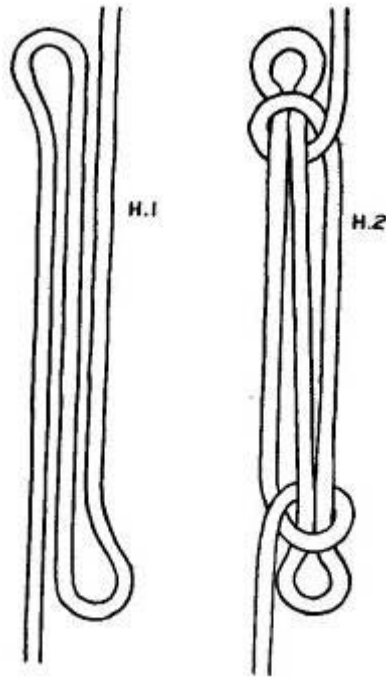

SHEEPSHANK (First Method)

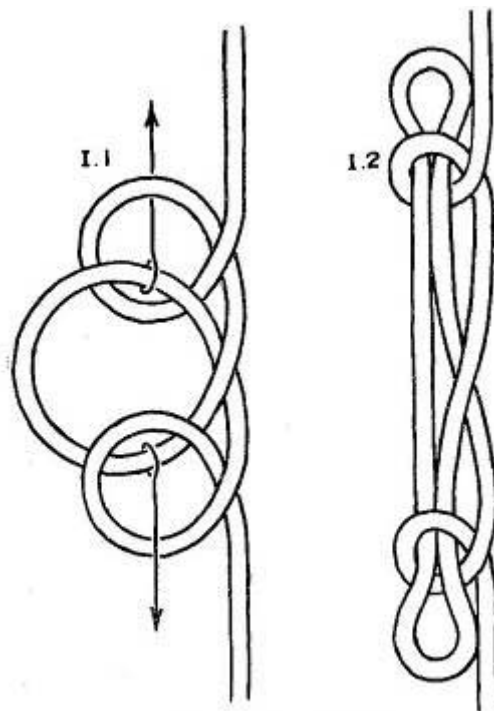

SHEEPSHANK (Second Method)

And now, to conclude this book here are two other knots, both simple and useful, which the Girl Guides do, and are well worth learning.

DOUBLE OVERHAND

To make a loop in the end of a piece of string or cord, quickly, take a bight in the end, make an overhand knot as in the sketch, and pull tight. The disadvantage of this knot is that it jams.

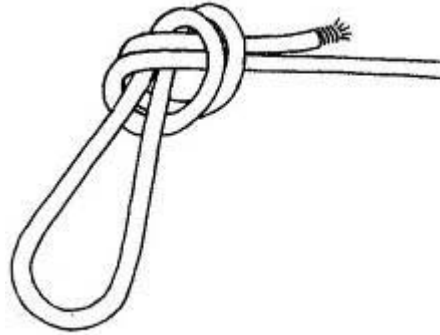

DOUBLE OVERHAND

PACKER'S KNOT

A very useful knot for starting to tie a parcel, made by passing the string or cord round the object to be tied, pass the end round the standing part, make a figure of eight, so that the end comes up through the loop in the same direction as the standing part. This is important.

Now pull on the end until tight, when you will be able to pull the standing part until it is tight enough to hold the parcel or whatever you are fastening. If you have done this correctly, it will not loosen, when you let the cord go, but to lock it in that position, throw a half hitch with the standing part over the end, and pull tight.

The sketch shows the knot loose, and the half hitch over the end, but it is no use unless pulled up as given above.

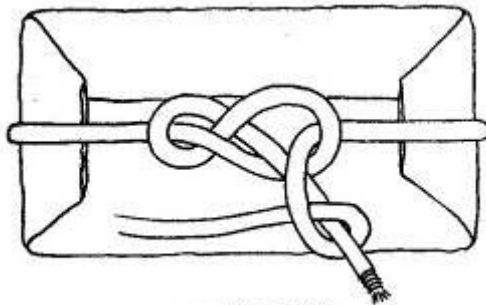

PACKER'S KNOT